



Using Digi products in the real world: Issues of grounding, isolation, and surges

February 2018

90000641

Contents

1	Introduction	5
1.1	Overview.....	5
2	Common serial media	5
2.1	EIA/RS-232.....	5
2.1.1	EIA versus RS	5
2.1.2	RS-232 basics	6
2.1.3	RS-232 and cabling	6
2.1.4	RS-232 and grounding.....	7
2.1.5	Surge-management tutorial.....	7
2.1.6	RS-232 and surge management	8
2.1.7	RS-232 and everyday data errors	9
2.2	EIA/RS-422.....	9
2.2.1	RS-422 basics	9
2.3	EIA/RS-423.....	10
2.3.1	RS-423 basics	10
2.4	EIA/RS-485.....	10
2.4.1	RS-485 basics	10
2.4.2	RS-422/485 basics	11
2.4.3	Two-wire versus four-wire	11
2.4.4	RS-422/485 and grounding	12
2.4.5	Grounded RS-422/485 circuits and grounding (EIA-485A option #2)	12
2.4.6	Isolated RS-422/485 circuits and grounding (EIA-485A option #1).....	13
2.4.7	RS-422/485 and surge management	13
2.4.8	RS-422/485 and everyday data errors	14
2.5	Comparison table of RS-232, RS-422, RS-485.....	14
2.5.1	When to use RS-232.....	14
2.5.2	When to use RS-422/485.....	14
3	How to know.....	15
3.1	Is your supply isolated or floating?	15

3.2	Is your device's serial port isolated or floating?	16
3.3	Should you use CAT-5 cable?	16
3.3.1	CAT-5 and shielding	16
3.3.2	CAT-5 and flexibility	16
3.3.3	CAT-5 and capacitance	16
4	Digi One IA and Digi One IAP (DIN-rail devices)	17
4.1	Overview.....	17
4.2	Using the direct DC power source.....	17
4.2.1	Grounding and RS-232	18
4.2.2	Grounding and RS-422/485	18
4.2.3	Grounding and Ethernet.....	19
4.3	Shielding.....	19
4.3.1	Serial cables	19
4.3.2	Ethernet cables.....	19
4.4	Surge management	19
4.4.1	Serial cables	19
4.4.2	Ethernet cables.....	20
4.5	Issues of ground potential problems with two devices.....	21
4.6	RS-485 on both ports of the Digi One IAP in pass-through	22
5	The Digi One SP (Single Port device server)	22
5.1	Overview.....	23
5.2	Using the Digi supplied AC/DC power source	23
5.2.1	Grounding and RS-232 with floating ground	23
5.2.2	Grounding and RS-422/485 with floating ground.....	24
5.2.3	Grounding and Ethernet with floating ground	24
5.3	Using the Direct DC power source	25
5.3.1	Grounding and RS-232 with grounded power	25
5.3.2	Grounding and RS-422/485 with grounded power	26
5.3.3	Grounding and Ethernet with grounded power	26
5.4	Surge management	26
6	Multi-port devices.....	27

- 6.1 Overview.....27
- 6.2 Issues of ground potential problems with multiple devices28
 - 6.2.1 The problem—Killer Ground Loops.....28
 - 6.2.2 Ultimate solution: Use isolated serial lines28
 - 6.2.3 Solution: Ground design at devices.....29
 - 6.2.4 Solution – Ground by-pass at Digi multi-port devices29

1 Introduction

Abstract

1.1 Overview

To ensure that your Terminal Server (TS) and Device Server (DS) products perform well, you must ensure these devices are properly installed. Specifically, issues of grounding, isolation, surge management, and shielding must be properly matched to your situation. The goal is a system you install once and forget about. Serial communications can be very robust and it is common for proper installations to work tirelessly 24/7 for a decade or more.

There is not one correct way to install a communications product. What works at one site will not necessarily work at another. Different sites have different combinations of needs or dependencies related to grounding, isolation, surge management, and shielding.

2 Common serial media

2.1 EIA/RS-232

2.1.1 EIA versus RS

Many people use the term “RS-232” loosely. When they refer to “RS-232” they are defining the application of TIA/EIA-232 parts that may or may not follow the standard strictly. When they refer to “TIA/EIA-232” they are implying that all parts of the system are strictly “per the standard.” For example, the original “EIA/RS-232-C” requires 25-pin connectors and a maximum speed of 9600 baud, so most products are not strictly EIA-232 compliant.

The electrical characteristics of RS-232 did not change significantly between revision “C”, “D”, “E”, and “F.” Most changes affected the behavior and naming of the various control signals. So, unless you are involved in international telephony or use specialized modem devices, you should find that devices claiming RS-232 C support operate similarly to those claiming TIA/EIA-232-F support.

For more information on the RS-232 standard and latest version, see the [RS-232 Wiki page](#).

2.1.2 RS-232 basics

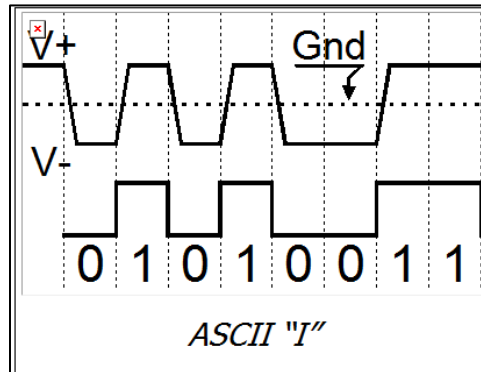

RS-232 is an interface standard, not a data communication standard. It can only go short distances and has very limited driving power. RS-232 was not designed to connect an industrial controller to a computer 100 feet away in another room.

RS-232 provides full duplex, point-to-point data transfer between two devices. The signal ground is included as one of the wires, so it is *very* susceptible to damaging ground loops. Data is transmitted as a voltage polarity relative to the common signal ground. The diagram above shows the signal for an ASCII character 'I.' When signal voltage is greater than +3 V, the data is a binary 0. When signal voltage is less than -3 V, the data is a binary 1. A voltage signal between -3 V and +3 V is undefined. For normal asynchronous serial lines, an idle line will be in the binary 1 state. This voltage signal is referenced to a ground that must be shared between both devices. It is quite susceptible to noise, ground and surge problems.

2.1.3 RS-232 and cabling

RS-232 has no specific distance limitation. Instead, the standard defines a capacitance limitation of 2500 pF per transmitter. This makes perfect sense when you remember what a transmitter must do. To change from a binary "0" to a binary "1," it must charge or discharge the wire to change polarity. So the higher the capacitance, the slower this change will occur. Since capacitance is accumulative with length, longer cables mean more capacitance. The often-quoted 15 m (49.2 ft) distance limitation is from an appendix to the specification that explains "this distance is a good rule of thumb when you do not know the specification of your cable."

Otherwise, using a quality low-capacitance cable with 42 pF/m (such as the Belden 1421A) means you can professionally run RS-232 over 55 m (180 ft). Note another rule of thumb—the thinner the overall RS-232 cable is, the higher its capacitive rating due to cross coupling between wires. So expect a low-capacitance cable to appear fatter than the cables you are accustomed to using.

Shielding is critical for RS-232. Never use unshielded cables for anything but bench-top trial runs. Unless your communications include error-detection codes, unshielded Ethernet CAT-5 cable is not suggested for professional RS-232 use. Assuming your devices are a company asset, the small cost savings of cheap cables is not worth the future troubleshooting headaches they can cause.

2.1.4 RS-232 and grounding

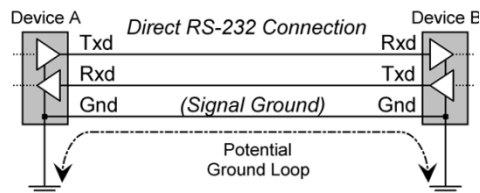

Look at the direct RS-232 connection above. Most engineers are trained to avoid multiple ground paths. However, this scenario is not uncommon, and in many cases the highest resistance found between the RS-232 signal ground and a device's chassis ground is only 0.9 OHMs. By definition, RS-232 requires this common ground to function. Note that this would not be a problem with a computer and modem sharing a common power source.

Thus, it is critical for EIA/RS-232 that one of the following two situations be true:

- Both devices must share a common ground with no ground potential difference.
- One device must isolate its RS-232 port to break any path to local ground.

The sections below discuss how this affects your selection and usage of Digi products. A good rule-of-thumb is that plugging both RS-232 devices into the same power strip virtually assures there will be no grounding problems.

2.1.5 Surge-management tutorial

The term “surge protection” can be a bit misleading. Surges occur because a higher voltage potential wants to dissipate to a lower voltage potential. Surges don't just go away. Therefore, you must provide paths for the surge to bypass your equipment. So really, surge protection is the art of *surge management*. It is important to understand where surges come from, where they want to go, and how to get them there without going through your equipment.

Surge management is the art of bypass, and can be lumped into three broad categories.

1. First, there is the high-voltage but tiny energy spark of static discharge or ESD. This is the shock you get when walking on carpet in the dry winter months. Most modern serial communication devices include ESD protection built into the actual receiver/driver chips. This is more to prevent failures from human handling during production and installation than an effort to provide surge protection for customers. Many cheap, office-grade surge devices are merely ESD filters, which you likely don't require. The tell-tale signs of ESD protection masquerading as surge protection are the rating of 15,000 V with no mention of current or energy (watts or joules). True surge devices require an energy rating. All Digi devices include 15,000 V ESD protection.
2. Second, there is transient or spike surge protection. This protection handles high-voltage, low-energy normal-mode spikes or noise surges induced in any long wire. These normal-mode surges are caused by the same phenomena as the pops and clicks you hear on your radio as you turn on or off devices. These can be identified in products by surge protection ratings in the 400 to 1500 W range. The voltage really isn't so important as long as the voltage plus current is low enough power to not burn out the surge or transient diodes used.

In general, you should assume transient surge protection is not included in a product unless

the vendor mentions it. Plus, if you see the 15,000 V rating, they are likely just talking about ESD protection. The Digi industrial products (like Digi One IAP) do include transient surge protection on the serial port. Other Digi products may require adding external surge protection if transient surges are expected. On multi-port products this is really a good thing—a “space” or air-gap is critical for effective surge management. Trying to squeeze surge protection into a tight product increases the probability of arcing as the surge ignores your herding efforts and passes through your device anyway.

3. Third, there is the heavy or lightning surge protection that can handle the very large energy of common-mode ground surges. The most common forms are gas-discharge tubes or spark gaps. Think of them as small neon tubes that convert much of the surge energy into heat and light. They are commonly rated in amperes or joules; for example 20,000 A or 10,000 J. This sounds like a lot of power, but the surge is of very short duration. One of the more common product tests for lightning protection is IEC 801.5, which uses a 6000 V, 3000 A surge with a specific pattern that peaks in eight microseconds and largely dissipates after 20 micro-seconds.

Most surge management solutions involve a mixture of “fine” and “coarse” protection. They use heavy surge devices to burn and bypass the majority of the surge energy. However, these devices are “coarse” (not very accurate). They may fire at any voltage between 150 to 400 V, meaning the attached device still needs to handle a low-energy 400 V surge. So low-energy surge diodes are added after the heavy devices as “fine” protection to clamp the remaining energy to within a few volts of the desired maximum.

Note that there is a fourth class of device, often called the varistor (variable resistor) or MOV (metal oxide varistor). They can be thought of as tens of thousands of surge diodes in parallel. They handle thousands of times more energy than a lone diode, plus have a much more accurate clamp range than gas discharge tubes or spark gaps. Unfortunately, they also have a very high capacitance that makes them more suitable for power circuits or DC signals. For example, the RS-232 limitation of 2500 pF is quickly passed when adding a 15,000 pF MOV to the line. They should be avoided for use in data communications where they will affect the signal. MOVs also have a tendency to progressively leak more current after every surge handled.

2.1.6 RS-232 and surge management

Since RS-232 runs the ground directly through the cable, proper surge protection is difficult. This is because the ground signal for RS-232 has almost no resistance from local chassis ground, making it challenging to offer surges a better path to ground. Major surge protection of RS-232 is only possible if the RS-232 port is isolated from the local ground. This isolation causes the path into your RS-232 port to appear as very high impedance (a very bad path to ground). Thus, the surge naturally uses your surge device and you effectively “herd” it to ground.

The TIA/EIA-232 standards require components to handle ± 25 V. Virtually all RS-232 circuits work between +12 V and -12 V, and ± 15 is the standard’s limit for normal operating voltages. So we suggest you plan for ± 15 V or ± 16 V surge devices, which means they tend to start protecting in the 18-20 V range. Selection of surge devices for RS-232 is limited by the need to keep capacitance below 2500 pF per wire. Surge diodes will add between 500 and 1000 pF

each, while varistors (or MOV) have as much as 15,000 pF each. So adding a surge device will shorten your overall permitted distance and greatly lower the permitted baud rate. Note that RS-232 is not suitable for lightning protection. To protect from lightning surges, it is best to use fiber optics or RS-485 with heavy surge protection.

2.1.7 RS-232 and everyday data errors

When used properly, RS-232 allows virtually error-free communications. This is not a feature of RS-232, just a side effect of the rather strict limitations on its usage. RS-232 is limited to a well-shielded, low-capacitance cable between two devices. These devices must be physically located close together without measurable ground potential differences or EMI disturbances.

If you cannot meet the strict RS-232 limitations, you should strongly consider switching to RS-422 or RS-485. Unshielded Ethernet CAT 5 cable is only suitable for short RS-232 cables or for use in applications that include error-detection and gracefully handle data errors. While you can sometimes run RS-232 for 61 m (200 ft) or more, this would be a mistake if data errors cannot be handled gracefully.

2.2 EIA/RS-422

2.2.1 RS-422 basics

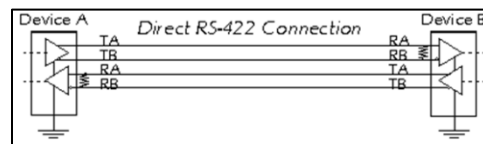

RS-422 and companion RS-423 were defined as fixes or replacements for RS-232. As opposed to an interface standard, RS-422 is a real data communication standard that includes realistic cable lengths and features to counter line noise. Instead of a single wire and voltage measured to a shared notion of ground, RS-422 introduces a pair of signals for a “differential signal.” The binary data value is defined by the polarity between the two wires without respect to ground.

See the [EIA/RS-485](#) section below for more discussion. Just think of EIA/RS-422 as EIA/RS-485 four-wire.

However, electrical ground is still important for RS-422 to function, as there must be a complete circuit for operation. The two wires in a pair are not a current loop. The RS-422 driver sources current on both wires and the receiver sinks current on both. So you must have a fifth signal return wire, or both devices must indirectly share the same ground through earth.

True TIA/EIA-422 devices are rare today, as the standard had some flaws that were resolved in RS-485. EIA-422 devices assumed no ground potential difference, didn't allow disabling a transmitter (so they could not be used for multi-drop), and had on-chip protection that (as specified) caused large current leakage when one device was powered on and the other off.

Most vendors claiming RS-422 support (Digi included) instead use chips supporting the much-improved RS-485 specification. Many vendors just use the term for historical reasons—they supported RS-422 and, when they converted to using RS-485 chips, they didn't change their

terminology. Some vendors reserve the term RS-422 to indicate a point-to-point link and the term RS-485 for a multi-point (or multi-drop) link. Still others use the term RS-422 to mean a multi-point RS-485 link with four wires and use the term RS-485 for a two-wire, half-duplex link.

2.3 EIA/RS-423

2.3.1 RS-423 basics

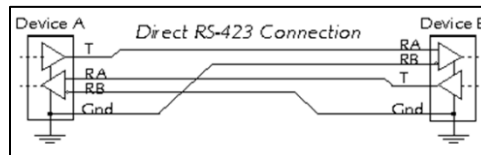

RS-422 suffers from the problem that two wires are required for each signal. Therefore, a traditional RS-232 cable with 25 wires would now require 50 wires. The RS-423 companion standard was included using an unbalanced design like RS-232 but including more robust features to cover realistic distances. Note the removal of the RS-232's assumption for a shared ground reference. RS-423 treats the remote ground as a pure voltage reference for data detection and does not mix it with its own local ground.

Few people use RS-423 these days. However, the standard was designed to simplify creating devices that could support both RS-232 and RS-423 on the same port. The place most people encountered RS-423 was in the world of 1980's mini-computers, which have evolved into today's workstations. A simple cable change allows connecting locally to an RS-232 device or up to 1,000 m (3,281 ft) away to another RS-423 device.

Digi doesn't directly support RS-423. We mention it because many industrial users encounter it when integrating mini-computer or workstation technology in SCADA or DCS systems. With Digi products, you'll need to use RS-232 or add third-party RS-232 to RS-423 converters.

2.4 EIA/RS-485

2.4.1 RS-485 basics

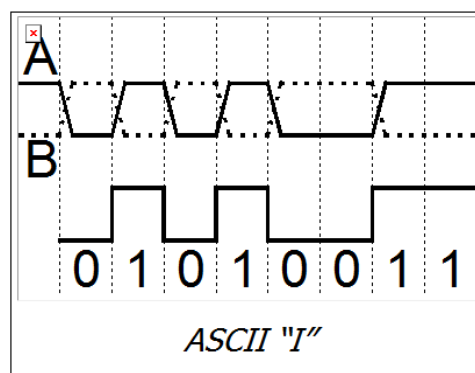

RS-485 is a half-duplex data communication standard that can be used for point-to-point or multi-drop applications. It uses twisted wire pairs. Data is transmitted by a differential voltage signal. The two wires in a pair are not a loop. Both are '+' (positive) signals sourcing current to a

third virtual ground conductor. For example, here is the differential signal for an ASCII character 'l'. Though labels vary from vendor to vendor, TIA/EIA-485 defines them as A and B. Data is represented by the relative voltage of A to B. When $V_A < V_B$, the data is a binary 1. When $V_A > V_B$, the data is a binary 0. An idle line without data is in the binary 1 state. An idle line without data is in the binary 1 state.

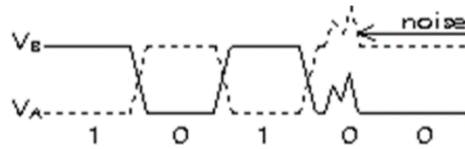

This differential voltage signal on a twisted wire pair is quite robust and less susceptible to noise or minor shifts in signal reference ground. The diagram above shows how minor noise on one wire induces a comparable noise on its mate. The noise does not affect the relationship between the voltage of wire A and B, so it does not lead to false data bits. In contrast, if this was an unbalanced signal such as RS-232, the noise on the solid line V_B may have approached 0v/ground enough to create a false data bit.

2.4.2 RS-422/485 basics

This is just a technical definition. Digi supports both RS-422 and RS-485 using TIA/EIA-485 compatible chips. True TIA/EIA-422 chips are rarely used today. So this document will use the term RS-422/485 to refer to any of these three connection designs—RS-422 as full-duplex four-wire point-to-point, RS-485 as half-duplex two-wire multi-drop, and RS-485 as full-duplex four-wire multi-drop.

2.4.3 Two-wire versus four-wire

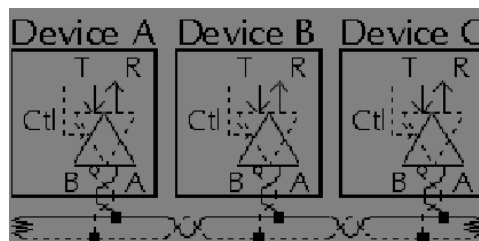

A two-wire RS-485 interface is strictly half-duplex. One wire pair is used as a bi-directional bus. Most devices use a master-slave design—where first a request is transmitted, and then a response is received. Other systems use complex token passing to allow multiple masters (or peers) to share the same half-duplex wire pair. Examples of such RS-485 networks are DH485 and ProfiBus. Many industrial products support both two- and four-wire RS-485. Providing terminals for four-wire, they allow external jumpers to short the two A signals and two B signals for two-wire.

A 4-wire interface uses two twisted wire pairs, one pair for transmit and one pair for receive. Masters use the Tx-pair to communicate with the slaves. Slaves use the Rx-pair to respond. Four-wire RS-485 is more robust than two-wire with low quality cable or high environmental

noise. It also reduces the data communication interrupt load on the slave devices since slaves only receive messages from the master and do not see other slaves' responses.

Note there is a special form of two-wire RS-485 that allows an optional second wire pair to be used as a control (RTS) signal to manage repeaters in the system.

2.4.4 RS-422/485 and grounding

Unfortunately, grounding for RS-422/485 is one of the most misunderstood aspects of serial communications. Many people believe that RS-422/485 does not require a ground. One myth is that the plus (+) and minus (-) signals act like a current loop and complete the electrical circuit by themselves. Another myth is that a differential signal just compares two voltages without reference to common ground. But the biggest culprit is the fact that RS-422/485 wired without proper grounding appears to work.

However, the truth is that both plus (+) and minus (-) signals source current during transmission and sink current when receiving. While the differential voltage signal can be compared without direct ground reference, an electrical circuit still requires a complete "loop" to operate reliably. Quoting the TIA/EIA-485A standard:

"Proper operation of the generator and receiver circuits requires the presence of a signal return path between the circuit grounds of the equipment at each end of the interconnection. The circuit reference may be established by a third conductor connecting the common leads of devices, **or** it may be established by connections in each, using equipment to an earth reference."

The reason RS-422/485 appears to work without proper ground consideration is that either the RS-422/485 devices are sharing a common earth reference through their power supplies (TIA/EIA-485A requirement #2) or there is enough leakage through the RS-422/485 on-chip protection circuits to approximate a common signal return (TIA/EIA-485A requirement #1). But professional users should understand how RS-422/485 works and select an appropriate ground design.

2.4.5 Grounded RS-422/485 circuits and grounding (EIA-485A option #2)

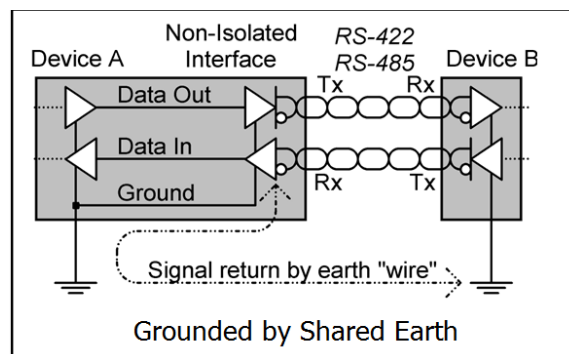

In an office environment, most RS-422/485 devices work with the notion of a grounded power supply. This is because, within a residential or commercial environment, all devices must reference themselves to the one common "safety earth" or "physical earth" (PE). The effect is

shown in the drawing above—as device A transmits to device B (sources a tiny current), the signal return completes the circuit through the shared notion of ground. But this only works if both devices ground themselves to the common earth. If either or both devices have a floating power supply, then the circuit is not complete. It functions because of phantom currents imposed on the RS-422/485 signals as each device transmits or receives.

This can be especially confusing because connecting the two grounds of these grounded devices together creates a ground loop, which can lead to catastrophic device failure. A ground potential difference between two such grounded devices can lead to amazing things. It could cause the communication wires to literally unsolder themselves from the connectors or melt, and/or the “magic smoke” may leave either or both devices and they will no longer function.

2.4.6 Isolated RS-422/485 circuits and grounding (EIA-485A option #1)

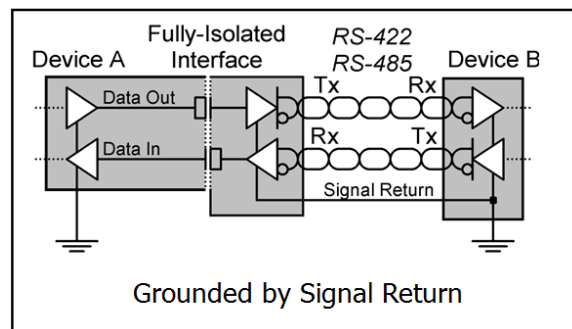

When either device in the RS-422/485 link has an isolated ground, then “a third conductor connecting the common leads of devices” is required. This is when the “signal ground” pins or terminals of the devices are connected. This drawing shows optical isolation in the RS-422/485 port, but the same concept applies if the power supply is isolated.

When in doubt, TIA/EIA-485A suggests users include a 100 OHM 1 W resistor in the ground wire at each attached device. This prevents common damage should a serious ground potential difference develop between devices with a ground wire. You can even add this to an RS-232 cable for safer connections.

2.4.7 RS-422/485 and surge management

The RS-422/485 interface is quite surge-management friendly. The chips only use the signal ground indirectly and are designed to handle minor ground potential differences of ± 7 V. Also, RS-422/485 is not as affected by capacitance. Thus, better surge-protection devices can be used with less impact on normal data communications.

The TIA/EIA-485 standards require components to handle voltages of ± 25 V. Digi suggests you plan for ± 15 or 18 V surge devices, which tend to function in the 18-20 V range. Some vendors suggest ± 6 V surge protection. *Do not use these.* Since the RS-422/485 chips used by Digi normally communicate in the range of -7 V to $+12$ V, clamping at ± 6 V can easily interfere with normal operations and even overload or damage power supplies. Using ± 15 V surge devices is just as safe as ± 6 V surge devices.

For the ultimate in surge protection, you can also convert RS-422/485 to fiber optics. This also eliminates grounding problems and can increase the overall distance you can cover.

2.4.8 RS-422/485 and everyday data errors

Running RS-422/485 a few dozen feet over quality cable with good shielding and ground can be virtually error-free. However, that's not what people use RS-422/485 for. Any electrical signal running over 1000 m of wire (such as 3300+ ft of antenna) will pick up noise. The differential twisted-pair nature of RS-422/485 helps reduce the impact of this noise, but you must assume a few communications errors occur every day. This means running long RS-422/485 lines is only suitable for protocols that include proper error-detect (a CRC or block-checksum).

RS-422/485 users should hope for 0% error but be able to function with 0.5% error.

Therefore it is inappropriate to run RS-485 for 700 m (2297 ft) for an application like a simple ASCII console or event-log printer. Byte errors in the first application could possibly change the remote device configuration and put it off-line, while the second application will see occasional control characters that affect printing.

2.5 Comparison table of RS-232, RS-422, RS-485

Both RS-485 and RS-232 have unique value as the best tools for certain jobs.

2.5.1 When to use RS-232

RS-232 is ideal for two nearby devices powered by the same power circuit. It is a very low-power signal, which helps your devices run cooler. The RS-232 standard is more consistently applied by various vendors, meaning you may have to make your cables, but the result will work.

2.5.2 When to use RS-422/485

RS-422/485 is better for devices that are farther apart than 15.2 m (50 ft) or when the quality of all grounds and powers is not known. Good examples are between different vendors' scope of supply or between functional areas in a plant (such as the home office and manufacturing). RS-422/485 can consume up to 100 times more power than RS-232, so make sure you have adequate power available. The main downside to RS-422/485 is that various vendors use conflicting jargon and designs. Interoperability can become a headache complete with trial-and-error testing. Issues of biasing, line-control and grounding can even make a few vendor combinations near impossible. You may need to add external resistors or even purchase signal converters to get products from diverse vendors claiming RS-485 to interoperate.

	TIA/EIA-232	TIA/EIA-422	TIA/EIA-485
Signal type	Unbalanced	Differential	Differential
Distance per standard	15 m (49.2 ft)	1000 m (3281 ft)	1000 m (3281 ft)
Practical distance with good cable	50 m (164 ft)	2000 m (6562 ft)	2000 m (6562 ft)
Maximum speed per standard	19200 bps	1M bps	1M bps
Number of devices connected	Point-to-Point	Point-to-Point	Up to 32
Number of conductors	3, 5, 7 or 9	4 (5 with gnd)	2 (3 with gnd) 4 (5 with gnd)
Cable type (all must be shielded)	Multi-core	Twisted pair	Twisted pair
Normal voltage range	+/- 15 V	0v to +6 V	-7 V to +12 V
Permitted ground potential difference	None	None	+/- 7 V
Receiver threshold	+/- 3 V	+/- 1.5 V	+/- 200 mV
Max short-circuit current permitted	100 mA	150 mA	250 mA
Min driver current expected	1 mA	22 mA	65 mA
Over-voltage protection per standard	+/- 25 V	+/- 25 V	+/- 25 V
Recommended surge device rating	+/- 15 V	+/- 15 V	+/- 15 V

3 How to know...

3.1 Is your supply isolated or floating?

You can measure this with a common resistance or digital multi-meter. There are fancier ways to measure it, but this will work. With your power supply disconnected, measure the resistance from the 0 V of the DC output to the neutral and ground (N and PE respectively) of the AC power side. Small AC/DC power packs tend to be isolated because they use a simple transformer. The AC/DC power supplies commonly used with notebook computers often have a grounded design to prevent ground discharges when connecting serial devices to the notebook. More expensive switching AC/DC power supplies often have some way to enable or disable connecting the frame ground to the DC 0 V ground.

3.2 Is your device's serial port isolated or floating?

You can measure this with a common resistance or digital multi-meter. With your device disconnected and without power, measure the resistance from the serial port's ground pin to the '+' and '-' terminals for power. If the resistance is infinite, then you likely have an isolated serial port.

It takes a thorough understanding of device design and the intended installation details to completely measure and interpret the results. The isolated or grounded feature is also affected by connections to metal chassis, the shield shell for Ethernet RJ and serial connectors, or explicit grounding terminals. For example, a device with 2000 V isolation between power and serial port has its isolation defeated if the serial ground ties to the shield shell that is then tied by the user to the same earth as the power supply. So installation becomes a critical factor in keeping or losing the benefits of isolation. The next sections will cover various Digi products and how they relate to issues of isolation, grounding, and surge protection.

3.3 Should you use CAT-5 cable?

It is important to use the right cables for your network. The "IEEE Category 5" (CAT-5) cable does have known impedance issues. You need to consider a few requirements for trouble-free data communications in order to create long-term solutions that minimize repair and downtime costs. When installing a system, a little extra effort to do it right always pays off in the end.

3.3.1 CAT-5 and shielding

RS-232/422/485 all work best with well-shielded cables. Using UTP cable starts your data communications off on the wrong foot with a higher probability of noise and surge problems. While you can buy STP cable, the thin foil used makes it error-prone when attempting to make well-shielded cables onsite. STP is most reliable with pre-made cables. Formal RS-232/422/485 cables are available with single or multiple layers of shielding and can include the bare "shield drain" wire required for reliable, hand-formed cables.

3.3.2 CAT-5 and flexibility

CAT-5 cable usually comes as a solid core, small-gauge wire. This is very susceptible to damage by bending, kinking, or repeated flexing. All standard RS-232/422/485 cables are stranded. If you must use CAT-5, consider one of the more industrial versions that include stranded wires.

3.3.3 CAT-5 and capacitance

High-quality CAT-5 cable may have a capacitance of about 15 pF/foot. Ignoring noise and line surges caused by lack of shielding, this allows normal UTP CAT-5 cable to run RS-232 about 53.3 m (175 ft) and still remain within the 2500 pF limitations. At that distance, grounding potentials are more likely to occur and damage your devices.

4 Digi One IA and Digi One IAP (DIN-rail devices)

4.1 Overview

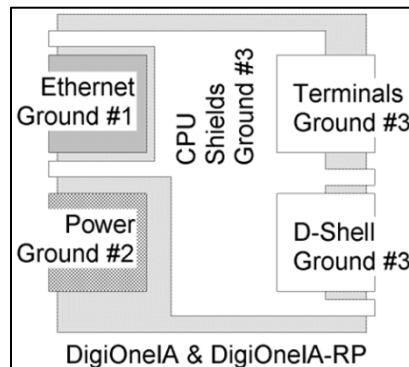

The Digi One IA device includes specific DC-to-DC isolation. The devices accept a 10 to 30 VDC supply and internally isolate that DC power by at least 500 V. Add to this the inherent isolation of IEEE mandated UTP Ethernet and the Digi One IA line is a product with three distinct grounds. If you use the 802.3af powered Ethernet option, this is also isolated internally so it remains related to the Ethernet Ground #1 above.

4.2 Using the direct DC power source

The Digi One IA line has floating-ground serial ports. The serial ports (Ground #3) in RS-232, RS-422, or RS-485 mode all float without reference to the local power supply (Ground #2). They will instead attempt to reference themselves to the ground of the attached serial device(s). Even if the remote device has a ground-potential difference of a few hundred volts, a Digi One IA device will connect and communicate. Ground #3 in the drawing above would have a similar large ground-potential difference from the Power Ground #2.

However, operating with such ground-potential differences in the long-term represents a shock hazard to employees. This ability is meant to allow full system operation during short-term ground-potential disturbances, like a flex-coupler between ground systems. The shock hazard exists because portions of the Digi One IA circuitry and shield shells could possibly have a large voltage potential compared to the local metal cabinets. This would be an eye-opening experience for a support technician assuming a low-voltage, touch-safe system.

If serious ground-potential differences are expected long-term, the only safe design is to add fiber optics to the serial link. This completely and safely decouples the Digi One IA device from the remote ground potential, eliminating the shock hazard. Since fiber optics are immune to noise and lightning surges, they should be considered anytime you run serial cable between buildings.

4.2.1 Grounding and RS-232

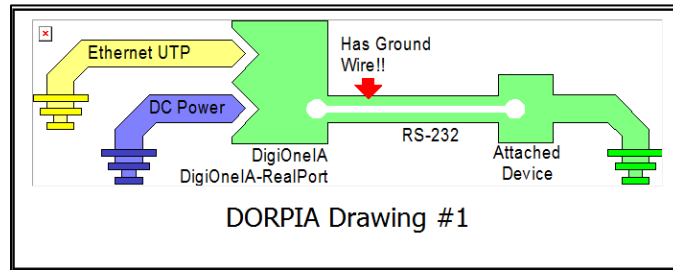

The Digi One IA device's floating RS-232 circuit readily references itself to the remote device's ground. This is ideal for complex or multi-vendor systems. While this Digi One IA RealPort wiring drawing (#1) shows three separate grounds, it doesn't matter how they relate. In most situations they will have identical voltage potentials. But even if fault conditions disturb this, it's not a concern.

4.2.2 Grounding and RS-422/485

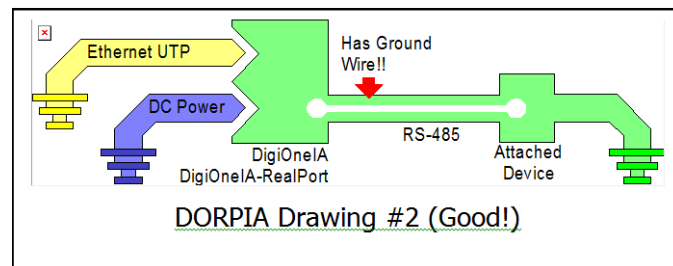

The Digi One IA device's floating RS-422/485 port complicates cabling a bit. By definition, the isolated Digi One IA device does not meet TIA/EIA-485A's Option #2 for signal return by "connections in each, using equipment to an earth reference." So we must meet TIA/EIA-485A's Option #1 for signal return by "a third conductor connecting the common leads of devices." This means we need three wires for RS-485 "two-wire" operation and five wires for RS-422 or RS-485 "four-wire" operation.

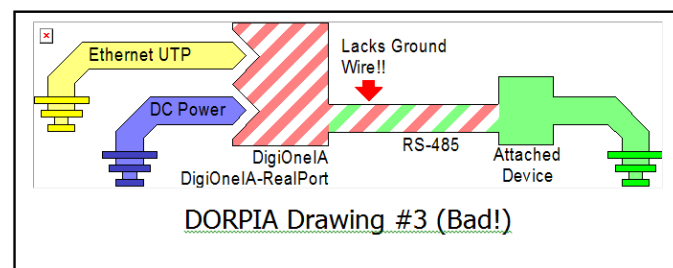

Will the Digi One IA device still work without this connection? Most likely, yes. However, its long-term reliability and survivability will be reduced. The problem is you have added a fourth ground—that of the floating Digi One IA device—and are improperly linking it by RS-485 to the remote RS-485 device. You have not followed TIA/EIA-485A requirements and included a signal return.

4.2.3 Grounding and Ethernet

The IEEE specification for UTP Ethernet requires 1500 V isolation transformers.

4.3 Shielding

4.3.1 Serial cables

RS-232/422/485 all perform better with proper cable shielding. Select a cable with a bare drain wire included; trying to properly connect shields directly to foil or braided shields is very error-prone. Shields must be connected (grounded) to something. A floating shield can create more noise problems than no shield at all. Shields must be connected at one end only. Connecting a shield at both ends allows large current flows through the shield that also add unwanted noise to the serial line.

The D-Sub Shell connector shell is grounded to the RS-232/485 signal ground. This means you can passively connect the shield through the cable shell. However, should you also ground the shield externally, this means you have shorted your floating RS-232/485 signal ground to that ground. Be careful you don't accidentally defeat the Digi One IA device's isolation this way. To maximize the value of the Digi One IA device's isolation, Digi recommends you tie your serial shield to ground at the remote device and not at the Digi One IA device.

4.3.2 Ethernet cables

The Ethernet shield is also tied to the Digi One IA device's floating RS-232/485 signal ground. Since most users will use unshielded (UTP) Ethernet cables, this won't be an issue.

However, if you decide to use shielded (STP) Ethernet cables, you need to consider this issue carefully. Digi recommends you connect the STP shield at the remote end only. If you do connect the shield at the Digi One IA device end, be aware that you have tied the shield to the digital ground of the Digi One IA device's floating RS-232/485 signal ground. This is not necessarily bad, but could lead to unexpected consequences. Also be aware that a floating shield generally causes more problems than no shield at all. So if you go with an STP design, you must include a detailed plan for how shields are connected and grounded.

4.4 Surge management

4.4.1 Serial cables

The Digi One IA device's serial ports already include transient surge protection. So you will not need to add external surge protection for normal-mode spikes and line noise. If you do, the range of ± 15 V to 18 V is the best choice as it works for RS-232, RS-422, and RS-485. Transient protection can be grounded to the serial signal ground or to a proper surge ground. Remember, the goal is "surge herding" or by-pass.

The small level of energy included in line spikes is not dangerous in itself, as long as it is allowed to by-pass your RS-232/422/485 chips. If you connect the surge output of these devices to a local surge ground, this will impact the isolation inherent in the Digi One IA device. Make

sure you take this into account in your design. Also, grounding surge devices near the device increases the likelihood of surge energy. The surge is just trying to get to a lower potential and adding earth-grounded surge devices is a good way to attract them toward your equipment.

If the Digi One IA device's serial lines run between buildings, between power systems, or between vendors' scope of supply, you should consider adding heavy common-mode lightning surge protection or converting to fiber optics. This is because at any moment in time you cannot really know how the remote device is grounded or the quality of that ground. What if a 100 kW motor faults all of its 480 VAC triple-phase power to the remote earth, creating a major ground-potential disturbance? What if a lightning strike or the design of a lightning protection system creates a large common-mode surge on your serial line? Or if a technician accidentally puts 110 VAC on your serial line? As a best practice, add the proper protection from the start and avoid the repairs and downtime.

The high energy involved in common-mode lightning or ground surges requires them to be properly grounded to a local surge earth ground. By-pass is not adequate. The surge energy wants to go to earth, and—if we don't offer a path—it may spark, arc, or jump across any isolation barrier or component standing in its way. The earth connection will affect your isolation. Additionally, providing a good path to earth at your devices requires the remote device to take proper surge precautions. Heavy surge protection is an all-or-nothing proposition. Either all devices involved have comparable protection or none should.

While a local surge earth connection reduces the isolation of the Digi One IA device, it is not wasted. The isolation inherent in the Digi One IA device makes any surge path through the Digi One IA device appear very high-impedance. In other words, a large surge entering your serial line will reach the surge device and have two potential paths to continue down. It can exit through the surge device and its low-impedance path to earth. Or it can continue on into the Digi One IA device and attempt to punch through the very high-impedance isolation barrier. This again leads us back to the herding notion. The isolation in the Digi One IA device guarantees all surge energy avoids the Digi device and uses your surge protection investment to pass harmlessly out to earth.

4.4.2 Ethernet cables

If the Digi One IA device's Ethernet connects directly to a local hub, switch, or router in the same cabinet, no special surge protection is required on the Ethernet port. If you are running the cable between buildings, panels, or power systems, you should add fiber optic or wireless media rather than Ethernet surge devices.

We are not saying the Ethernet surge devices on the market don't work. We are just pointing out that trying to surge protect wired Ethernet is a trade-off. A surge device must appear as high-impedance and have minimum impact on the signal during normal operations. However, to route the surge energy away from the data line it must rapidly detect a surge and change from open circuit to short circuit. A strong surge protection design may adversely affect the signal during normal operations. A weak surge protection design may not act fast enough to protect your equipment. And what is fast protection response for a 9600 baud RS-232 signal (i.e. 10 kHz), is not fast to 100 MHz Ethernet (i.e. 100,000 kHz). Using fiber optics or wireless Ethernet

not only side steps this trade-off, it also reduces grounding and noise issues while greatly increasing the permitted end-to-end distance to many kilometers.

4.5 Issues of ground potential problems with two devices

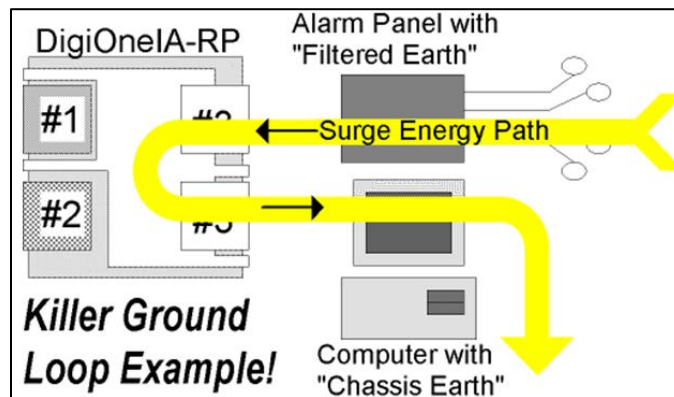

The Digi One IAP device allows the two serial connectors (one D-Shell and one screw terminal) to act as one or two ports. This allows two serial devices to share the Digi One IAP device. (This does not apply to the Digi One IA device.) The pass-through port allows a serial master (such as PC/HMI or local operator panel) to share a single-port serial slave with the network. Special firmware helps manage the priority of these shared masters to prevent the serial master from being starved by heavy network master demands.

On the downside, this potential opens the Digi One IAP device up to a classic killer ground-loop problem. Remember the Digi One IAP device has three separate grounds internally. The isolation between the Ethernet port, power supply, and serial ports is still valid. However, both serial ports still share a common ground. This is not a problem when both serial devices share a common ground externally. But it makes the Digi One IAP device become an expensive fuse if they do not.

The drawing above shows a classic "Killer Ground Loop." For safety and ease of troubleshooting, industrial or building-automation systems with lots of remote sensors use a filtered or floating earth. This means any surge energy entering the system is assumed to exit through specific inductors and surge protection paths. However, if they have a non-isolated RS-232 port, then the floating RS-232 earth of a Digi One IAP device will reference itself to this filtered earth.

This is an excellent feature, and the exact reason the internal ground isolation in the Digi One IAP device is a critical industrial feature. However, connecting the second RS-232 cable to a common PC computer is the source of the "Killer Ground Loop." The PC computer assumes the metal chassis is ground, which in turn connects directly to the safety or PE ground in your building's AC mains or power system. This is the third ground conductor added to most modern devices. Now any surge energy entering the alarm system will see a lower impedance path to ground by exiting the RS-232 port, passing through the Digi One IAP and the second RS-232 into the PC computer.

A low-energy surge will likely not damage the Digi One IAP device, but may destroy the PC computer's RS-232 port and possibly even its CPU and motherboard. A high-energy surge taking this path will likely kill the RS-232 ports on both connected devices and could even melt the PCB board in the Digi One IAP device (which is how it can become an "expensive fuse").

The solution to this problem is quite easy. One of the two external devices (either the alarm panel or the PC) must have an isolated port. Because the alarm panel uses a filtered earth, it really should have an isolated RS-232 port even if this is an option that costs extra. However, because a modern multi-GHz computer is a very sensitive device, one could argue that purchasing isolated serial ports for it is also a must. If either of these two options is not available or too expensive, there are many third-party suppliers selling RS-232 isolators that can be used for any RS-232 connection. Regardless of which device is isolated, one or both must make the new Digi One IAP device "pass-through" feature a long-term, robust solution. Adding surge management devices could partially compensate for this ground loop problem. However, it is only a partial solution. Adding RS-232 isolation is a complete solution.

4.6 RS-485 on both ports of the Digi One IAP in pass-through

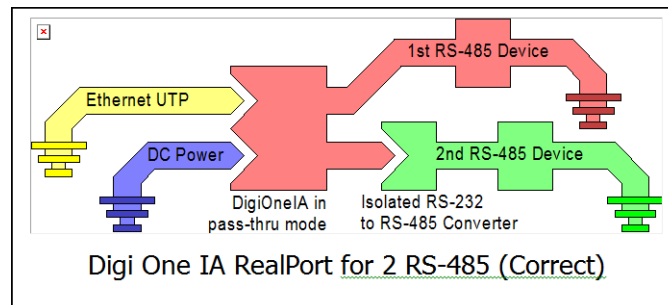

The Digi One IAP device only supports RS-232 on the DB-9 in pass-through mode. The primary reason is lowering overall cost. Many people do not need the second port or pass-through mode, so Digi didn't want this function to force an across-the-board price increase.

However, it does have a secondary benefit. Since the two ports of the Digi One IAP device are not isolated from each other, running RS-485 direct to two very different field devices has a fairly high probability of ground damage to the Digi One IAP device. In order to support dual RS-485 ports, the Digi One IAP device would need to support full optical/galvanic isolation between the two. This would add perhaps \$100 to the overall cost. Those requiring a second RS-485 port should invest in a good isolated RS-232 to RS-485 converter. They will gain not only a second RS-485 port, but also achieve full isolation between the two RS-485 systems.

5 The Digi One SP (Single Port device server)

This section describes the Digi One SP in contrast to the Digi One IAP, which is described in [section 4](#).

5.1 Overview

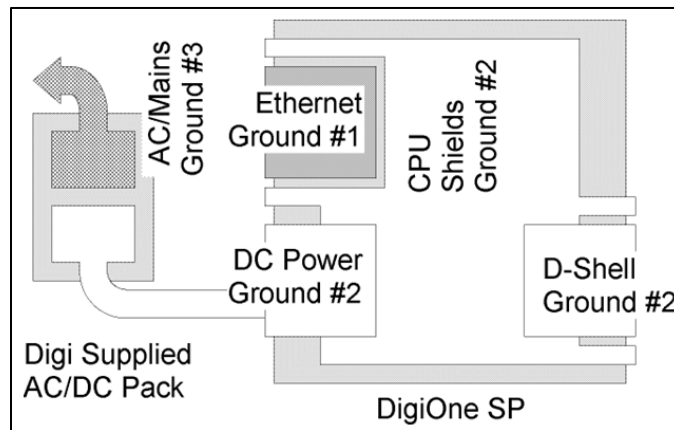

The Digi One SP device does not include internal DC-to-DC isolation. This is a normal design for small single-port device servers. It accepts a 9 to 30 VDC supply, but the DC ground (or 0 V) is assumed to be the same as the shield and serial ground. Ground isolation is included in the Digi-supplied AC/DC power pack. This creates a third ground external to the Digi One SP device. Add to this the inherent isolation of IEEE-mandated UTP Ethernet, and the Digi One SP device is a product with two distinct grounds internally—plus a third implied ground if isolated DC power is supplied. If you use the 802.3af powered Ethernet option, this is also isolated internally so remains related to the Ethernet Ground #1.

5.2 Using the Digi supplied AC/DC power source

Unless you understand ground-system design, Digi highly recommends you use the isolated AC/DC power pack supplied with the Digi One SP device.

5.2.1 Grounding and RS-232 with floating ground

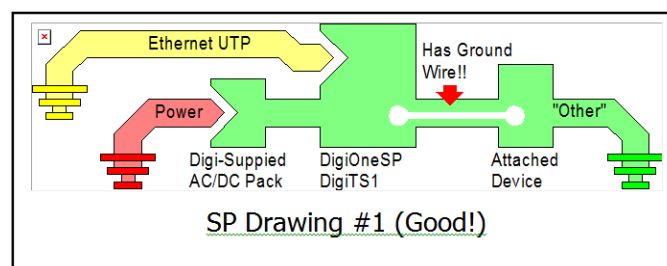

The Digi One SP device used with an isolated AC/DC supply allows the floating RS-232 circuit to readily link and reference itself to the remote device's notion of ground. Given the sensitivity of RS-232 to ground loops, using an isolated DC supply with the Digi One SP device is always the preferred solution. Digi One SP Drawing #1 clearly shows this situation. Three distinct grounding systems are created. How these systems are linked externally is not our concern—our design works regardless.

First is the Ethernet UTP ground, which references itself elsewhere and we don't need to worry about it. Second, is the AC mains power ground, which references to the safety earth as part of

the electrical codes. Third, is the “Other” ground defined by the attached device. This other ground will likely be the same as the AC mains power ground, but the beauty of a well-designed ground and isolation system is that it doesn’t matter. Your Digi One SP device will work just fine should the other ground be floating, filtered, or even tied to another power system. We have not made any assumption about this other ground, so changes done at the attached device do not affect the Digi One SP device.

5.2.2 Grounding and RS-422/485 with floating ground

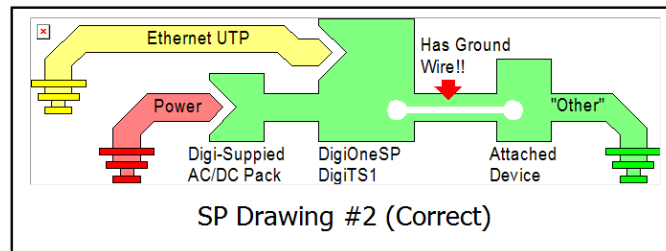

The Digi One SP device is used with an isolated AC/DC supply that creates a RS-422/485 circuit with floating ground. The ideal wiring includes an explicit ground wire to tie the Digi One SP device to the other ground. So your RS-485 two-wire becomes three, and four-wire becomes five. Discussion of the three grounds shown is the same as for SP Drawing #1.

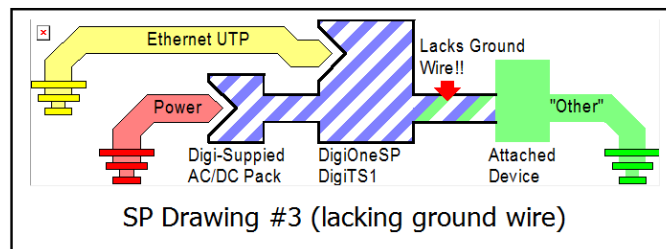

You should not run a pure two-wire or four-wire RS-485. The problem is shown in Digi One SP wiring Drawing #3. This is a bad design. The floating RS-422/485 of the Digi One SP device has created a fourth ground that is being improperly linked by the RS-485 chips to the other ground. Yes, the Digi One SP device still works without proper serial grounding, but you’ll find long-term reliability and survivability is reduced. A common symptom of RS-422/485 with improper grounding is that, while it works great 99.9% of the time, you may lose communications a few hours each week or month. Go to [section 3](#) for drawings of how to properly ground your RS-422/485.

5.2.3 Grounding and Ethernet with floating ground

The IEEE specification for UTP Ethernet requires 1500 V isolation transformers. Thus, the Digi One SP device’s Ethernet port is always isolated and not affected by use of an isolated or non-isolated power.

5.3 Using the Direct DC power source

Since the Digi One SP device accepts DC power supply of 9 to 30 VDC, many people are tempted to share existing central 12 V or 24 VDC supplies. This is perfectly acceptable, but you must understand the consequences—using a non-isolated DC power causes the Digi One SP device's serial ground to be tied to the power ground.

5.3.1 Grounding and RS-232 with grounded power

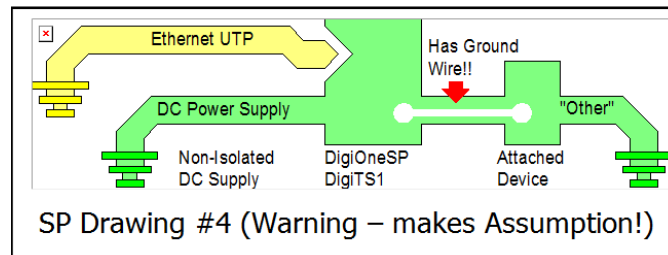

Using a shared DC power supply instead of the AC/DC supply from Digi means the Digi One SP device's RS-232 circuit is referenced to the power supply ground. So you have the potential for ground loop currents entering the Digi One SP device's RS-232 port to reach the power supply ground. Notice that the DC Power Supply Ground has been assumed to be the same as the other ground. You have built a dependency or assumption into the system that may not be true today or after any future changes to the system. The RS-232 signal ground has less than 1 OHM of resistance to the power supply ground. Thus, any RS-232 port can easily be damaged by ground currents should the DC power supply ground and the other ground be different—even for a fraction of a second—during a system fault.

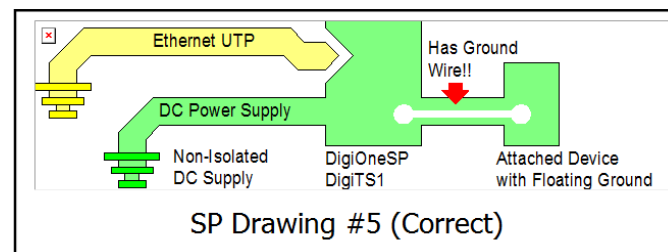

Using the Digi One SP device with non-isolated DC power is fine when you connect a device with a floating or isolated serial port, or one that uses the same DC power supply. Most small devices with external AC-power-packs (such as barcode scanners, and weight scales) have an RS-232 port with a floating ground. Of course you have built a dependency or assumption into the system that may not be true after any future changes to the system. You need to make sure future device replacement doesn't introduce a ground loop such as the one in Digi One SP wiring drawing #4.

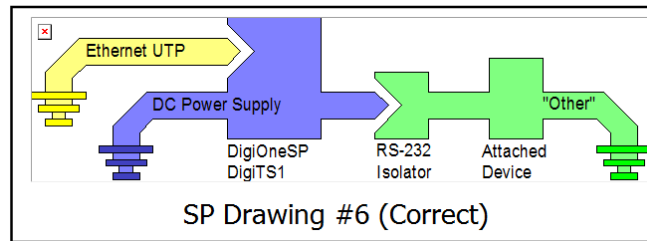

The ideal design when using a non-isolated DC power supply with the Digi One SP device is to add an external RS-232 isolator. These break the ground path and prevent ground loop currents through the RS-232 cable. Cost for external isolators ranges, depending in part on what features they include. For example, some include LED indicators, special connector types, and/or serious surge protection.

When in doubt, the safest design with the Digi One SP device is to either use the Digi-supplied, isolated AC/DC power supply, or to add an external RS-232 isolator.

5.3.2 Grounding and RS-422/485 with grounded power

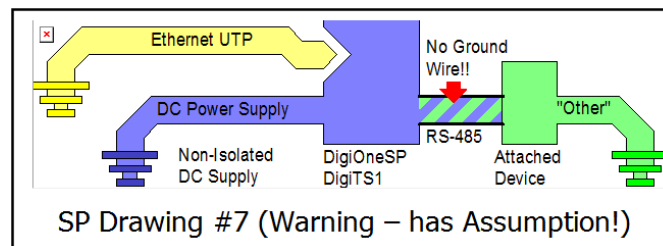

Using a shared DC power supply instead of the AC/DC supply from Digi means the Digi One SP device's RS-422/485 circuit is now referenced to the power-supply ground. While you still have the potential for damaging ground-loop currents, the RS-422/485 chips have thousands of OHMs of impedance. This reduces the likelihood of damage.

This actually can be a good thing. If the remote RS-422/485 device is also grounded in the same manner, you can now run a pure two-wire or four-wire design. You are still assuming the ground potential difference between the DC power supply ground and the other ground will never be greater than ± 7 V. However, this is safer than adding the third (or fifth) ground wire to the RS-422/485. The explicit ground wire would cause substantial ground currents to flow with even a 1 to 2 V ground potential difference.

5.3.3 Grounding and Ethernet with grounded power

The IEEE specification for UTP Ethernet requires 1500 V isolation transformers. Thus, the Digi One SP device's Ethernet port is always isolated and not affected by use of isolated or non-isolated power.

5.4 Surge management

The Digi One SP device's serial port does not include transient surge protection. It does have 15,000 V ESD protection, but that's another topic. If you expect normal-mode spikes and line

noise on the serial port, you should add external transient surge protection in the range of ± 15 V to 18 V. This works for RS-232, RS-422, and RS-485. Do not use ± 6 V surge protection for RS-422/485 since the RS-485 chip within the Digi One SP device is designed to operate from -7 V to $+12$ V.

If you plan on adding heavy lightning protection to the Digi One SP device, it is safest to use the Digi-supplied isolated AC/DC power supply. This makes the surge path in or out of the Digi One SP device by power cable very high-impedance, and high-impedance is the greatest surge-deterrent available. Successful lightning protection is possible with a Digi One SP device and a central, shared DC power supply. However, you must know what you are doing. The heavy surge currents during lightning storms can be very unpredictable. You may even have surges entering other devices pass through the DC power supply and damage the Digi One SP device to reach its attached lightning protection. This is why using an isolated power supply is safest to ensure the path in or out of the Digi One SP device power cable is high-impedance.

6 Multi-port devices

The following section assumes you have read [section 4](#) on the Digi One IAP and [section 5](#) on the Digi One SP. This section just covers the issues for multi-port devices. In addition, when we refer to the DigiOne TS2 port device below, assume the same applies to other multi-port devices.

6.1 Overview

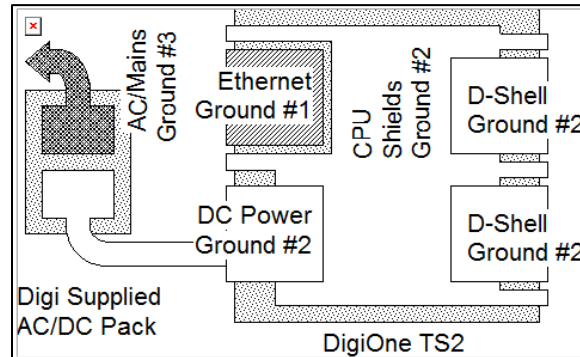

Digi multi-port devices do not include internal DC-to-DC isolation. As far as grounding, isolation, and surge protection goes, they are nearly identical to the Digi One SP device (for more information please read [section 5](#)). The one big difference is that 2 to 16 serial ports all share a common ground with the DC power supply.

6.2 Issues of ground potential problems with multiple devices

6.2.1 The problem—Killer Ground Loops

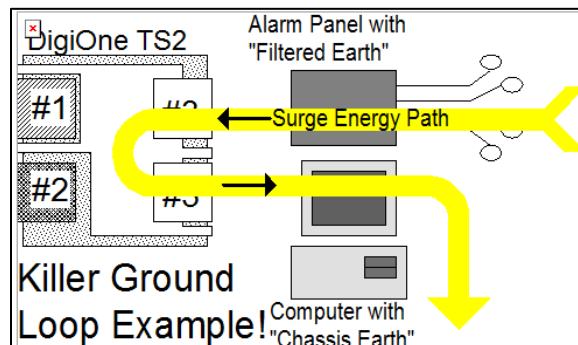

This is really the same problem we discussed with the Digi One IAP device used as a two-port device. But because two, four, eight, or even 16 devices are involved, the probability of killer ground loops occurring is much higher. If the connected devices are all the same make and model from a single vendor, killer grounds are less likely. However, if you are mixing devices from various vendors, then you should assume killer ground loops are highly probable.

6.2.2 Ultimate solution: Use isolated serial lines

For the ultimate solution that you install once and never need to maintain, you just need to make sure all serial lines are isolated.

Most small devices powered by an AC power pack have a floating earth by design. The AC transformer in the power pack creates a low-voltage DC supply without direct connection to the AC earth. However, when people see four devices and four power packs (all running at say, 9 to 12 VDC), they often consider using a single power supply for all four. But this does not promise they all have the same serial ground. The use of protection diodes in many devices means even sharing a DC supply will end up with serial grounds varying by up to 1.5 V. This will lead to phantom currents in the serial lines. In fact, it is common for the entire product current (say 100 or even 800 mA) to enter one device from the power supply then exit that device and return to the power supply through the RS-232 cables and the device.

For grounded devices, or those with shared DC supplies you may need to add external serial isolators. They are available with isolation from 500 to 5000 V. Some claim to be self-powered, but reliable communications are highly dependent on the attached device. The newer multi-port devices (with MEI or RS-232/422/485 ports) allow extra power to the ports. Some port devices should only have externally powered isolators. But you cannot assume the attached device can adequately power its half of the isolator. Using a self-powered isolator with the wrong devices could create a support headache because higher errors and occasional communications outages occur. The best practice is to design in powered isolators. They cost a bit more, but you can be sure they work reliably for years to come. Powered isolators strengthen the signal, while self-powered isolators weaken it.

6.2.3 Solution: Ground design at devices

The lowest cost (but error-prone) solution is careful ground design. You need to make sure all connected devices share a single concept of ground. This can be done with probable success by any of the following methods.

- Make sure all devices plug into a single power strip and make sure you provide documentation for support staff that this must remain true. This is where the “error-prone” feature comes into play. Even if you install the system with a single power strip, what is the probability that a few years from now that will still be true? People are too used to the idea that AC power is power and that any AC outlet will do.
- Study every device, locate its main ground, and then tie all the device’s grounds together with large gauge ground wire. This should likely be connected to the safety or PE earth in the AC power system. Larger three-prong devices likely do this already, but many of the small two-prong devices (or three-prong devices with two-conductor power wire) will lack an explicit ground connection. This suffers the same dynamics as using the same power strip—over time these ground connections will disappear. If you don’t fully understand grounding, it is possible that doing this incorrectly will create more serious ground problems or violate health and safety codes.

6.2.4 Solution – Ground by-pass at Digi multi-port devices

Installing external surge protection on all serial lines near the multi-port device can help prevent ground loop damage to the device. It does not stop ground-loop problems. It just offers related surge energy a by-pass to avoid passing through the device. The surge may still damage the attached devices, but it should spare the device. This solution is only appropriate when ground loops are not expected. For example, this could be a good compliment design when the same power strip powers all connected devices.

