



TransPort™ WR31

Analog and Digital Input/Output Interface

User Guide

TransPort WR31 Analog and Digital Input/Output Interface User Guide

90001489

Revision	Date	Description
A	December 2015	Initial release.
B	January 2016	<ul style="list-style-type: none">• Added correct spacing in the following CLI commands:<ul style="list-style-type: none">▪ ss460140>gpio dio -d0 ON▪ ss460140>gpio diopullup -d1 off• Updated copyright year.
C	December 2019	<ul style="list-style-type: none">• Added information about the gpio aincal command.

Product documentation

To find the most up-to-date documentation for all Digi products, visit www.digi.com/resources/documentation.

Trademarks and copyrights

TransPort, Digi, Digi International, and the Digi logo are trademarks or registered trademarks in the United States and other countries worldwide. All other trademarks mentioned in this document are the property of their respective owners.

© 2019 Digi International. All rights reserved.

Disclaimers

Information in this document is subject to change without notice and does not represent a commitment on the part of Digi International. Digi provides this document “as is,” without warranty of any kind, expressed or implied, including, but not limited to, the implied warranties of fitness or merchantability for a particular purpose. Digi may make improvements and/or changes in this manual or in the product(s) and/or the program(s) described in this manual at any time.

Warranty

View the product warranties online: <http://www.digi.com/howtobuy/terms>

Contents

TransPort WR31 input/output interface

- I/O connector pin assignments 4
- Wiring the I/O connectors 5
- Hardware specifications and configuration 5
 - Digital I/O schematic 5
 - Analog input schematic 6
 - Analog input 6
 - Digital input 7
 - Digital output 8
 - Configure the I/O interface 9
- Additional information 9

TransPort WR31 input/output interface

The TransPort WR31 input/output (I/O) connections are a general purpose I/O interface. The main features of the I/O interface include:

- 1 analog input
- 2 digital input/output (software-selectable)

I/O connector pin assignments

The TransPort WR31 has a 5-pin I/O connector. The I/O connector, pin assignments, and signals for each pin are shown in the following image and table.

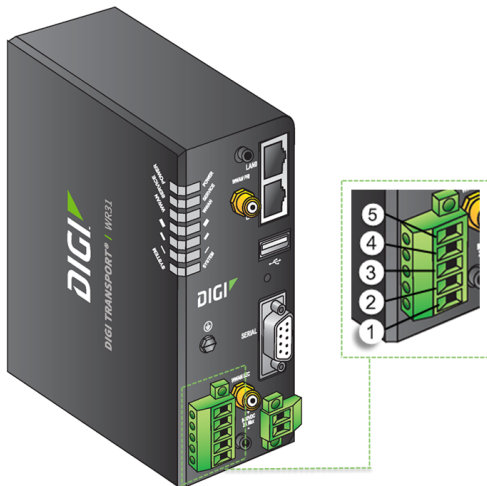

Pin number	Assignment	Signal
5	AIN0	Analog input 0 (zero)
4	AGND	Analog return
3	DIO0	Digital I/O 0 (zero)
2	GND	Digital return
1	DIO1	Digital I/O 1 (one)

Wiring the I/O connectors

A 5-pin terminal female connector is included for wiring.

The following image shows how to secure the wires using the screw-down clamps. The connector is attached to the TransPort WR31 with the screw flanges. We recommend using the wire size 16-26 AWG for the 5-pin terminal.

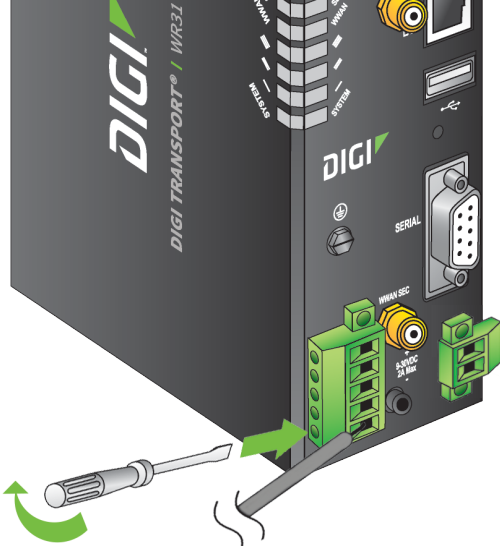

Hardware specifications and configuration

The following section provides the specifications and configurations of the TransPort WR31 I/O Interface.

Digital I/O schematic

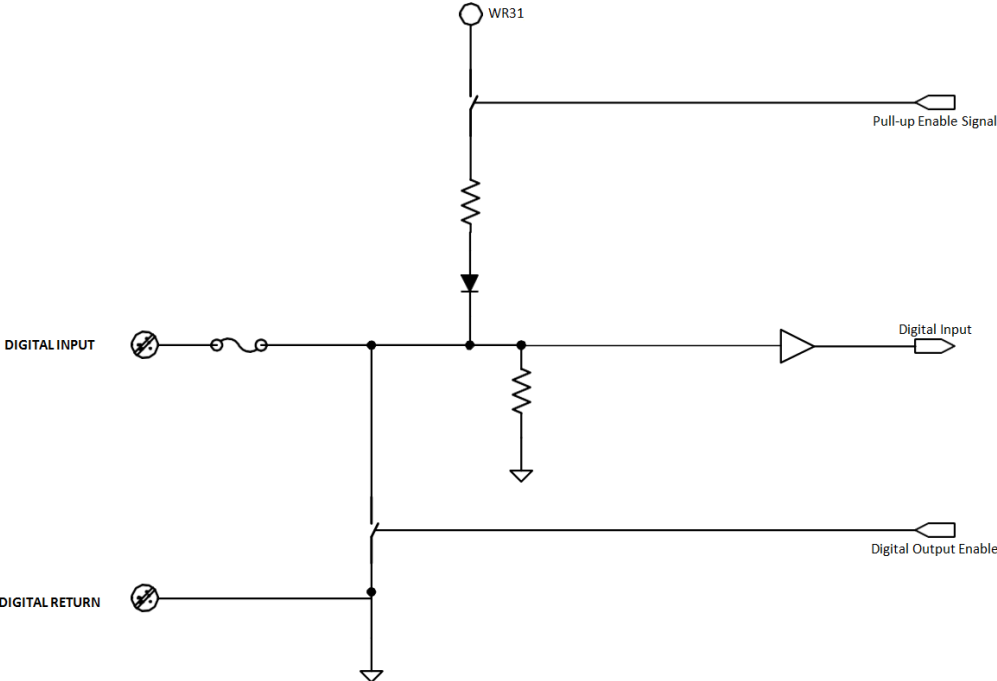

Analog input schematic

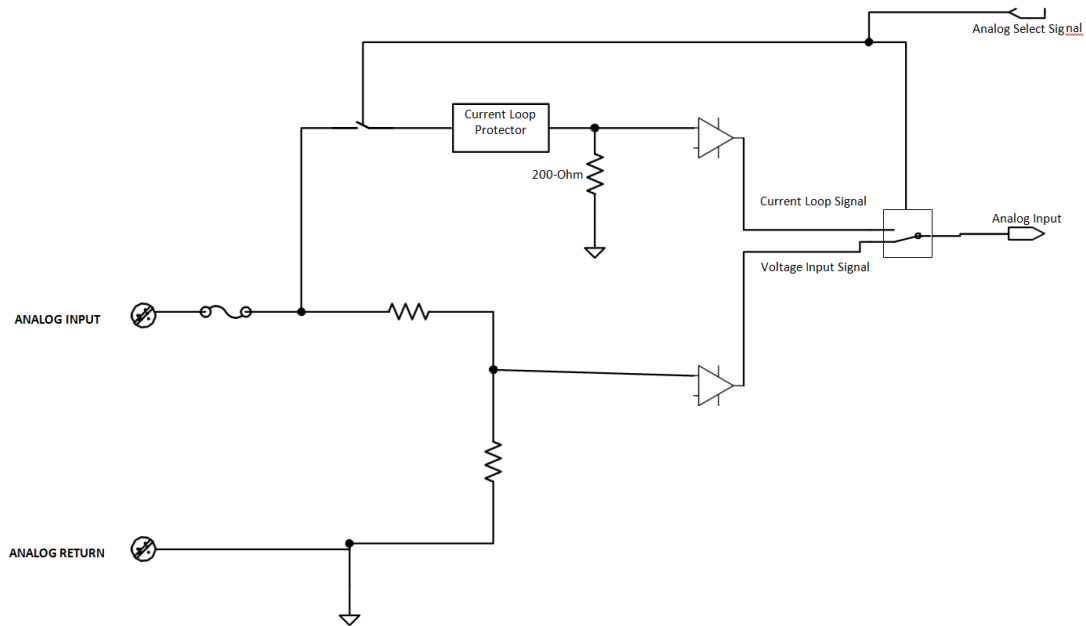

Analog input

The analog input port has the following two modes of operation:

- Voltage monitor: The TransPort WR31 is configured to monitor a voltage input from 0V to +10V.
- Current-loop monitor (default mode): The TransPort WR31 is configured to monitor a current-loop input from 4mA to 20mA. The minimum input voltage is 2.0V.

The following figure shows the voltage monitor (analog input, 0-10V input) mode schematic.

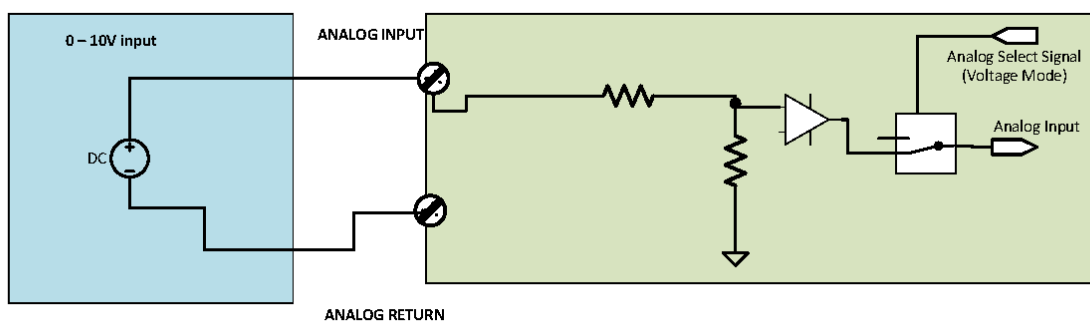

The following figure shows the current-loop monitor (analog input, 4-20mA) mode schematic.

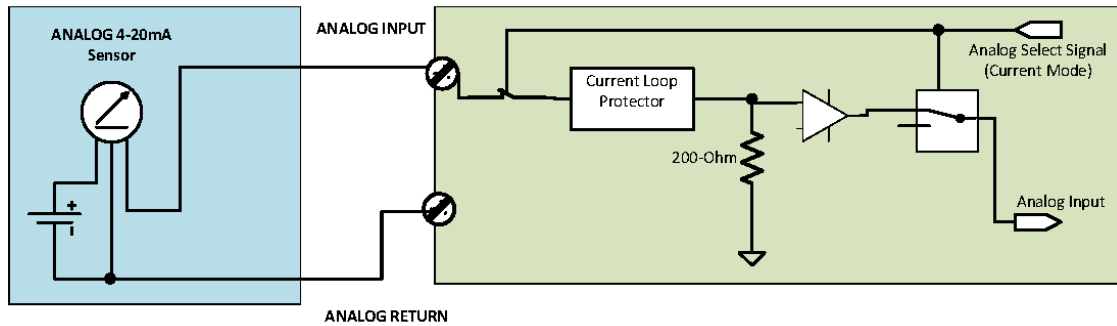

Digital input

The digital input port has the following two modes of operation:

- Internal power mode (default mode): The digital input port uses an internal pull-up to indicate state in the absence of an external supply. You can also use this for switching low-voltage contacts.
- External power mode: The battery symbol indicates that an external power source is in use (see the external power mode schematic). The maximum voltage that can be supplied is 30VDC.

The following figure shows the internal power mode schematic.

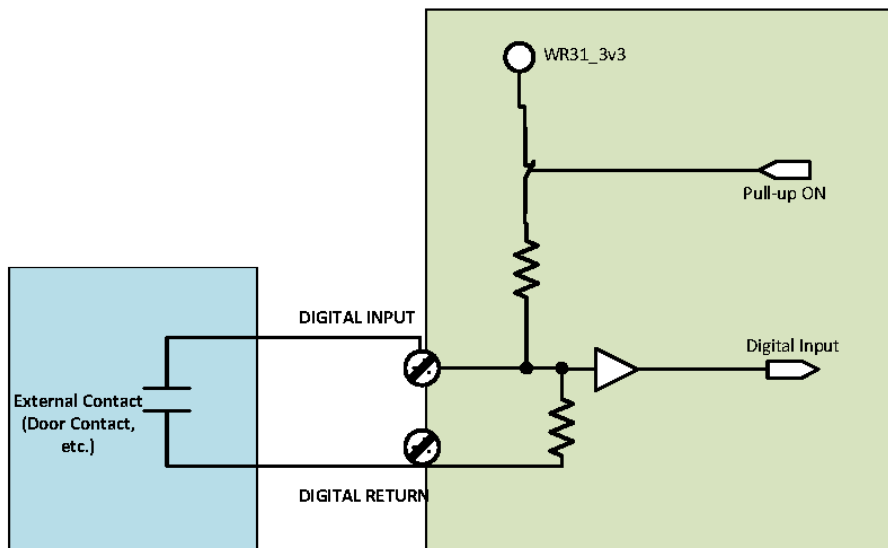

The following figure shows the external power mode schematic.

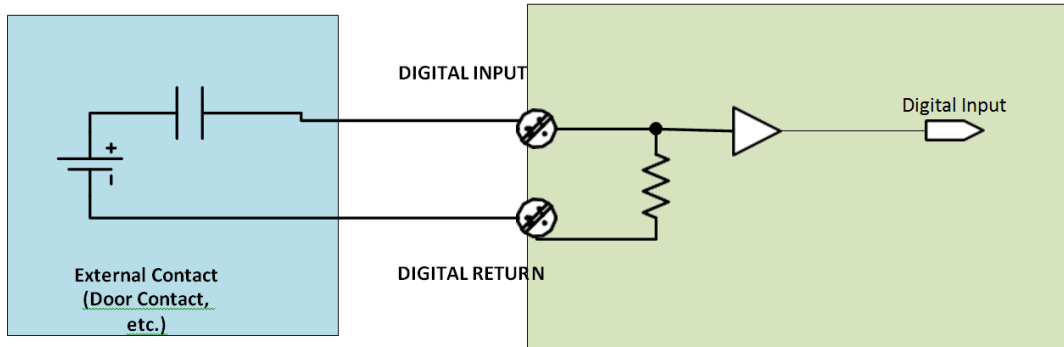

Digital output

The digital-out configuration is a transistor drain to the user. The maximum collector current is 200mA and must be user-limited.

The following image shows a schematic of the typical digital-out application.

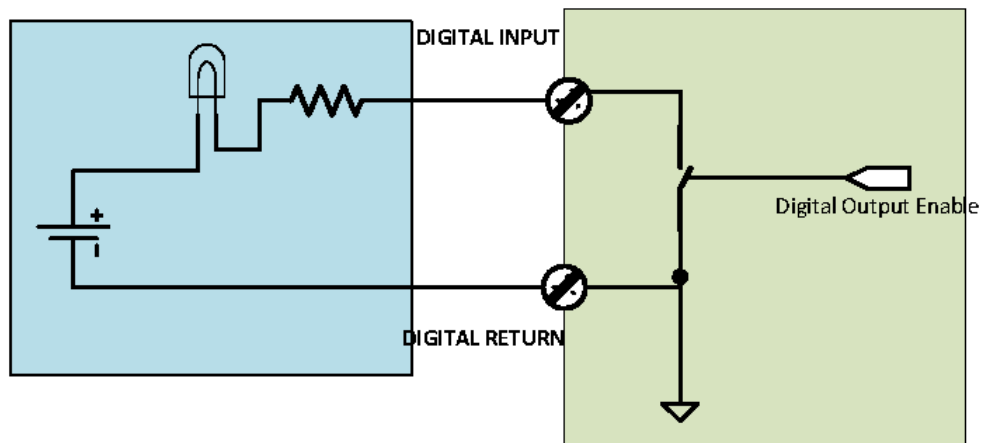

Configure the I/O interface

To configure the TransPort WR31 I/O interface, use the command line interface (CLI) commands. You can build these commands into Python or Basic scripts to automate functionality, or use them manually in the CLI.

The **GPIO** command is the main command for the TransPort WR31 I/O interface. The following table summarizes GPIO use.

Command	Description
<code>gpio ain [current voltage]</code>	Analog input control
<code>gpio aincal Low High <V> <mA></code>	Calibrates the analog input. Each mode (current or voltage, as selected by <code>gpio ain</code>) is calibrated separately. Low and high values may be entered for each mode. The values entered by the user must be read off an external volt (V) or current (mA) meter, up to four decimal places.
<code>gpio aincal show</code>	Show analog input calibration data
<code>gpio aincal reset</code>	Erase all analog input calibration data
<code>gpio dio [{-D0-1 on off}]</code>	Digital input/output control
<code>gpio diopullup [{-D0-1 on off}]</code>	Digital input/output pullup control

The following shows CLI dialog examples of the analog input commands. User input is **bold** and device response is plain text.

```
ss460140>gpio ain current
A0: voltage=0.7420 V
OK
```

```
ss460140>gpio ain voltage
A0: current=1.7051 mA
OK
```

The following shows CLI dialog examples of the digital input commands. User input is **bold** and device response is plain text.

```
ss460140>gpio dio
D0: DOUT=ON, DIN=HIGH (Inactive)
D1: DOUT=ON, DIN=HIGH (Inactive)
OK
```

```
ss460140>gpio dio -d0 ON
D0: DOUT=ON, DIN=HIGH (Inactive)
ON
```

```
ss460140>gpio diopullup -d1 off  
D0: Pullup=ON  
D1: Pullup=OFF  
OK
```

Additional information

For more information and Python code examples for using the TransPort WR31 analog and digital I/O interface, visit https://github.com/digidotcom/transport_examples.